

# Bulk Deformation Processes



Bachelor of Industrial Technology Management with Honours  
Semester I Session 2013/2014

# TOPIC OUTLINE

- What is Bulk Deformation?
- Classification of Bulk Deformation Processes
- Types of bulk deformation processes
  - ✓ Forging
  - ✓ Extrusion
  - ✓ Drawing
  - ✓ Rolling

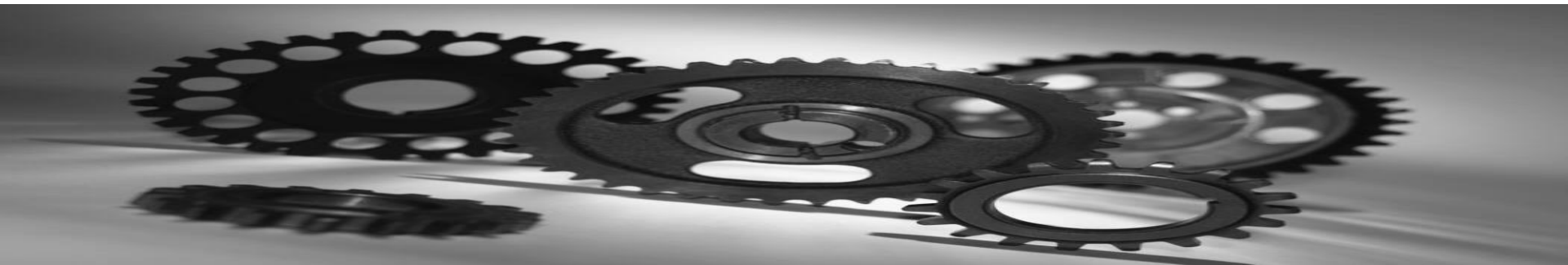

# LESSON OUTCOMES

1. Able to differentiate between the hot, warm and cold working of bulk deformation.
2. Able to explain the bulk deformation processes.



# What Is Bulk Deformation?

- Operations that induce shape changes on the metal work piece by plastic deformation under forces applied by various tools and dies.
- Starting forms: cylindrical bars and billets, rectangular billets and slabs, and similar shapes.
- These processes work by stressing metal sufficiently to cause plastic flow into desired shape.
- The cross-section of work piece changes without volume change.
- Advantages:
  1. Produces common shapes inexpensively.
  2. Good mechanical properties.

# What Is Bulk Deformation?

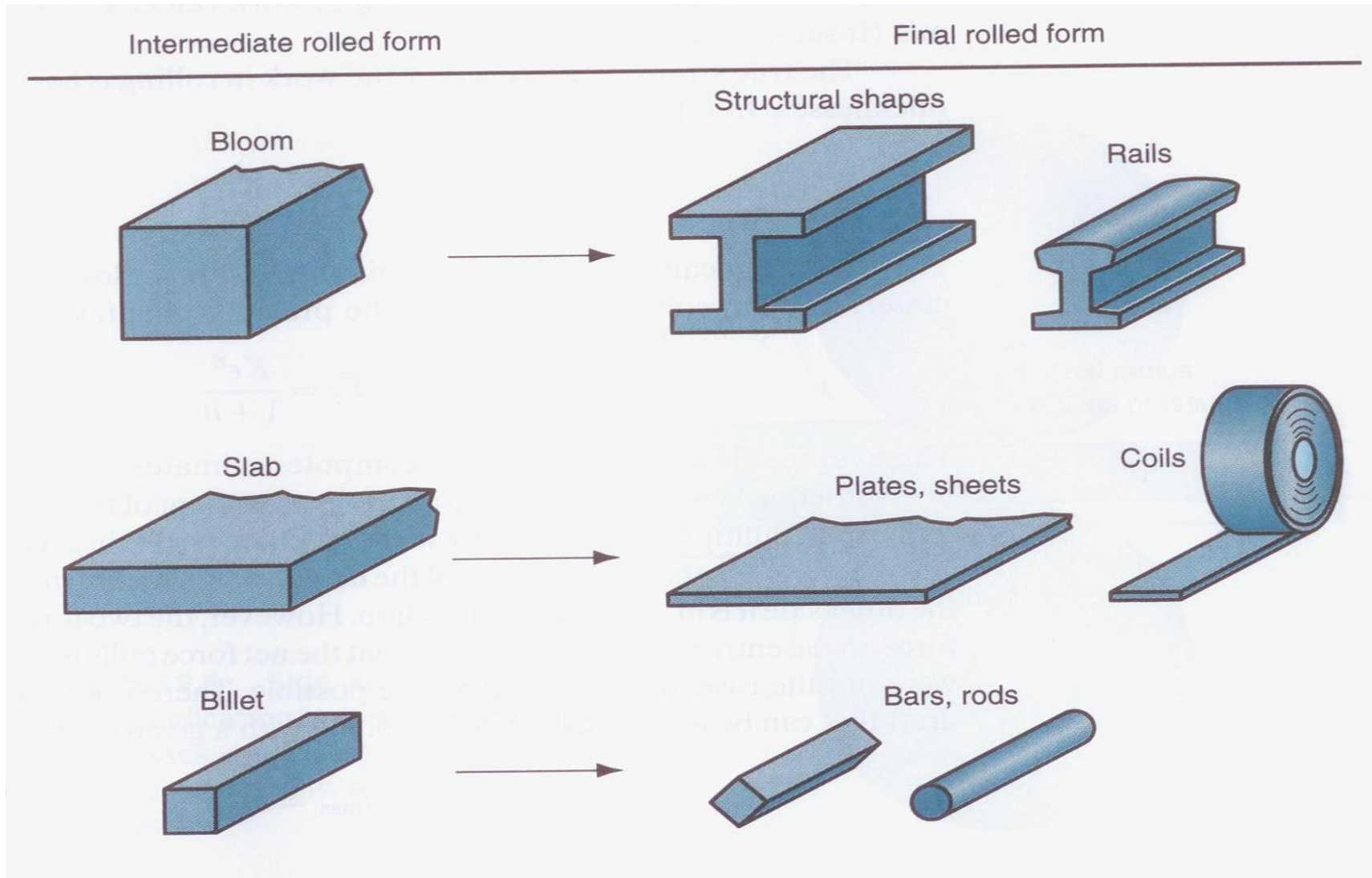

# Classification Of Bulk Deformation Processes

## Cold Working

- Metal forming performed at room temperature

---

<b>Advantages</b>	<b>Disadvantages</b>
Better accuracy	Higher forces and power
Better surface finish	Limitations to the amount of forming
High strength	Additional annealing for some material is required
Hardness of the part	Some material are not capable of cold working
No heating is required	

# Classification Of Bulk Deformation Processes

## Warm Working

- Metal forming performed at temperature above the room temperature but below the recrystallization condition

---

### Advantages

Lower forces and power

More complex part shapes

No annealing is required

### Disadvantages

Some investment in furnaces is needed

# Classification Of Bulk Deformation Processes

## Hot Working

- Involves deformation of pre-heated material at temperature above the recrystallization temperature

---

### Advantages

### Disadvantages

Big amount of forming is possible

Lower accuracy and surface finish

Lower forces and power are required

Higher production cost

Forming of materials with low ductility

Shorter tool life

No hardening work - no additional annealing is required

---



# Types Of Bulk Deformation Processes

## **Forging**

- ✓ The work piece is compressed between two opposing dies so that the die shapes are imparted to the work.

## **Extrusion**

- ✓ The work material is forced to flow through a die opening taking its shape.

## **Drawing**

- ✓ The diameter of a wire or bar is reduced by pulling it through a die opening (bar drawing) or a series of die openings (wire drawing).

## **Rolling**

- ✓ Compressive deformation process in which the thickness of a plate is reduced by squeezing it through two rotating cylindrical rolls.

# Types Of Bulk Deformation Processes

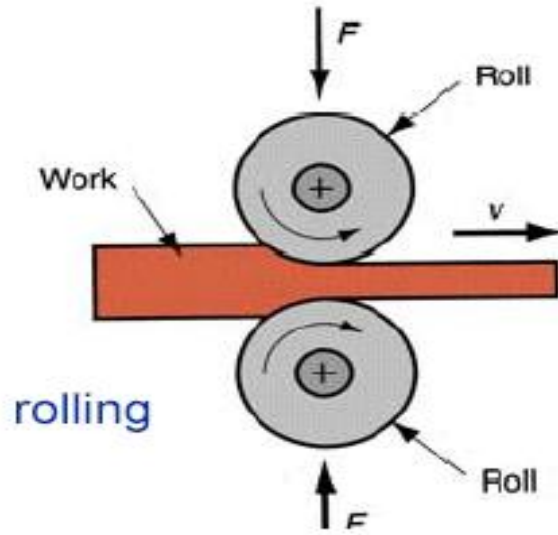

rolling

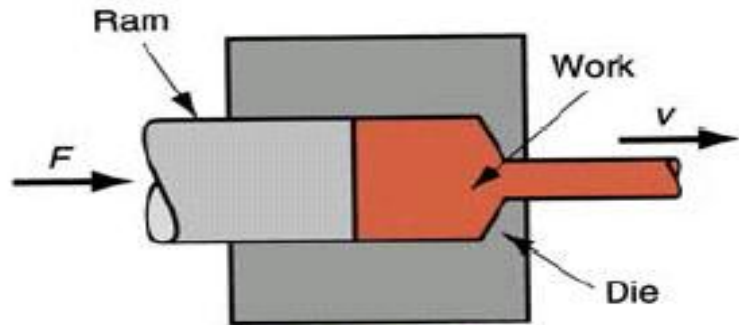

extrusion

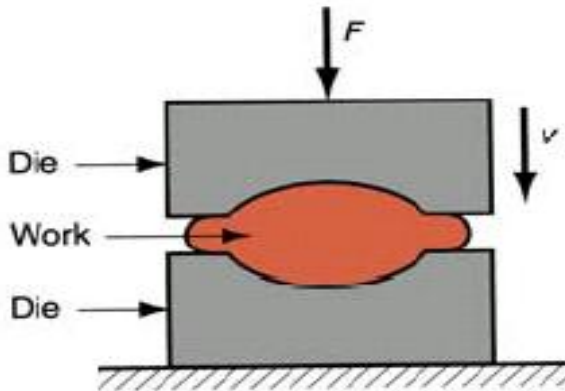

forging

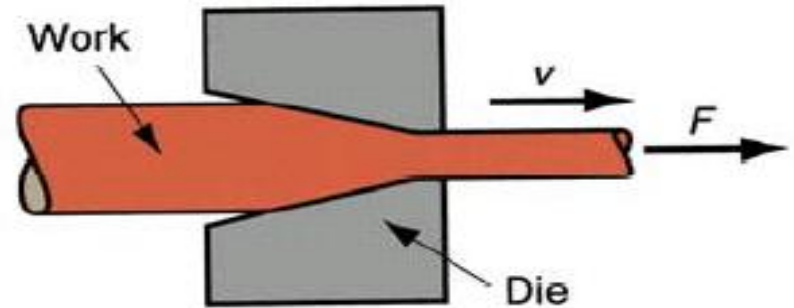

Wire/bar drawing

# Forging

- Process in which the work is compressed between two dies / mould
- Some finishing operations are necessary
- Dies and equipment costs are high
- Involves moderate to high labor costs
- Require moderate to high operator skills
- Three types of forging:
  1. Open-die forging
  2. Impression-die forging
  3. Flash-less forging

# Forging

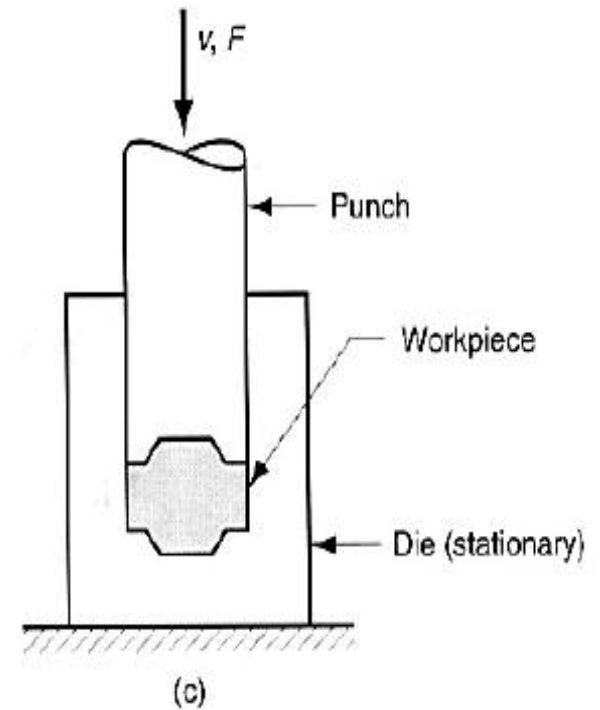
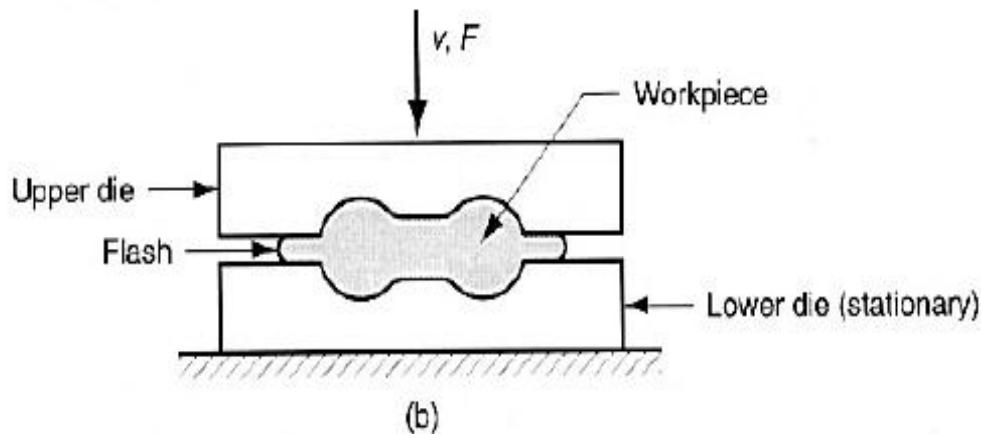
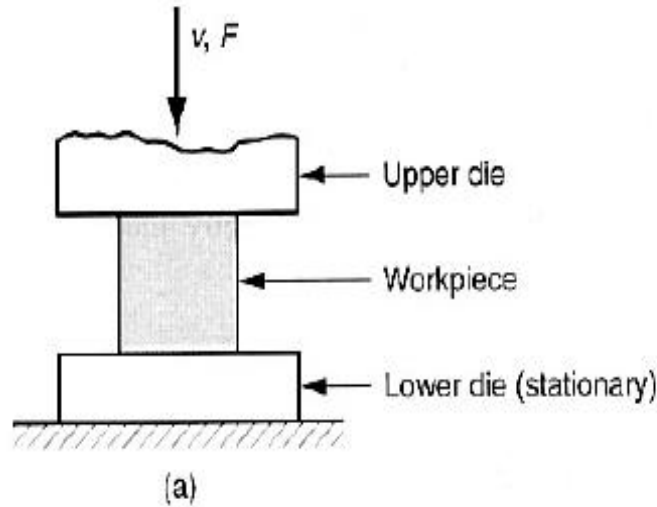

Three types of forging: (a) open-die forging, (b) impression die forging, and (c) flashless forging

# Forging

## Open-die forging

- Known as upsetting, it involves compression of a work between two flat dies or platens.
- Operations reduces height and increases diameter of work.

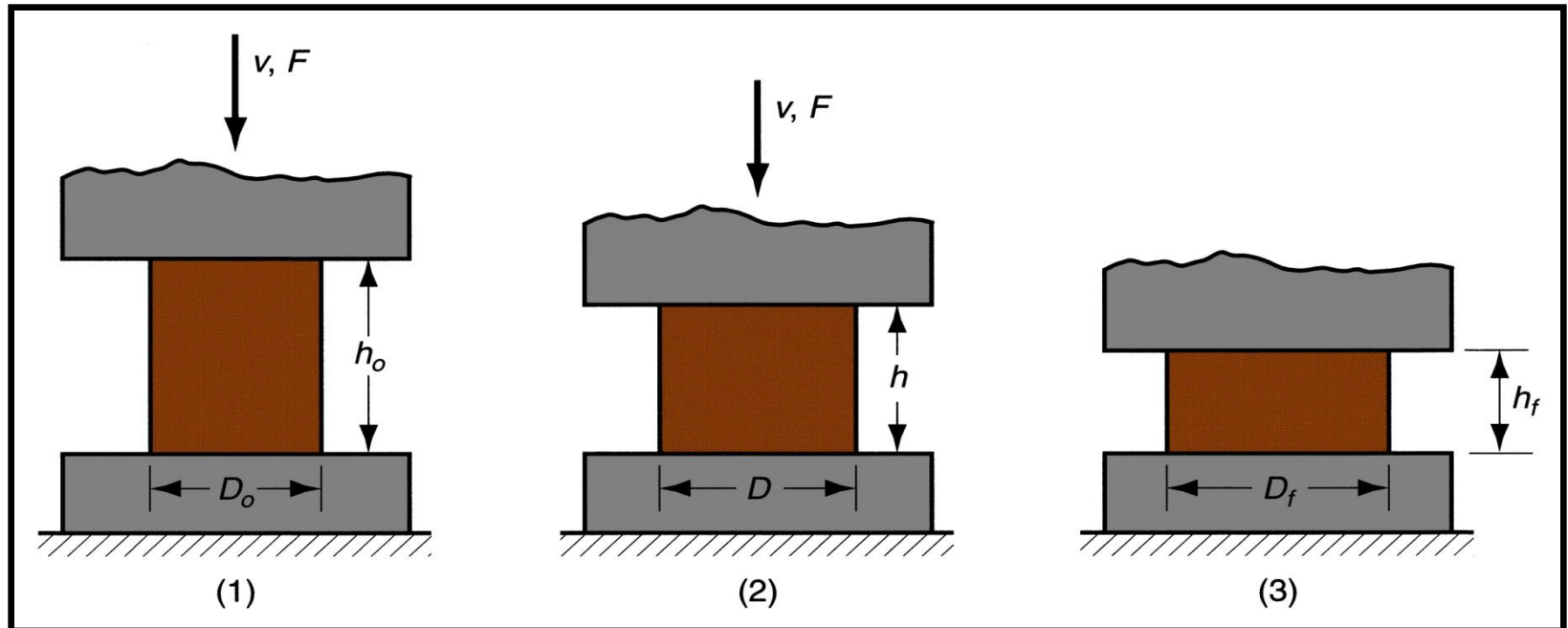

# Forging

## Advantages:

1. Simple and inexpensive dies
2. Wide range of part sizes
3. Good strength characteristics
4. Generally for small quantities

## Disadvantages:

1. Limited to simple shape
2. Difficult to hold close tolerances
3. Machining to final shape necessary
4. Low production rate

# Forging

Barreling : caused by frictional forces at the die-work piece interfaces.  
Can be minimized by effective lubricant.

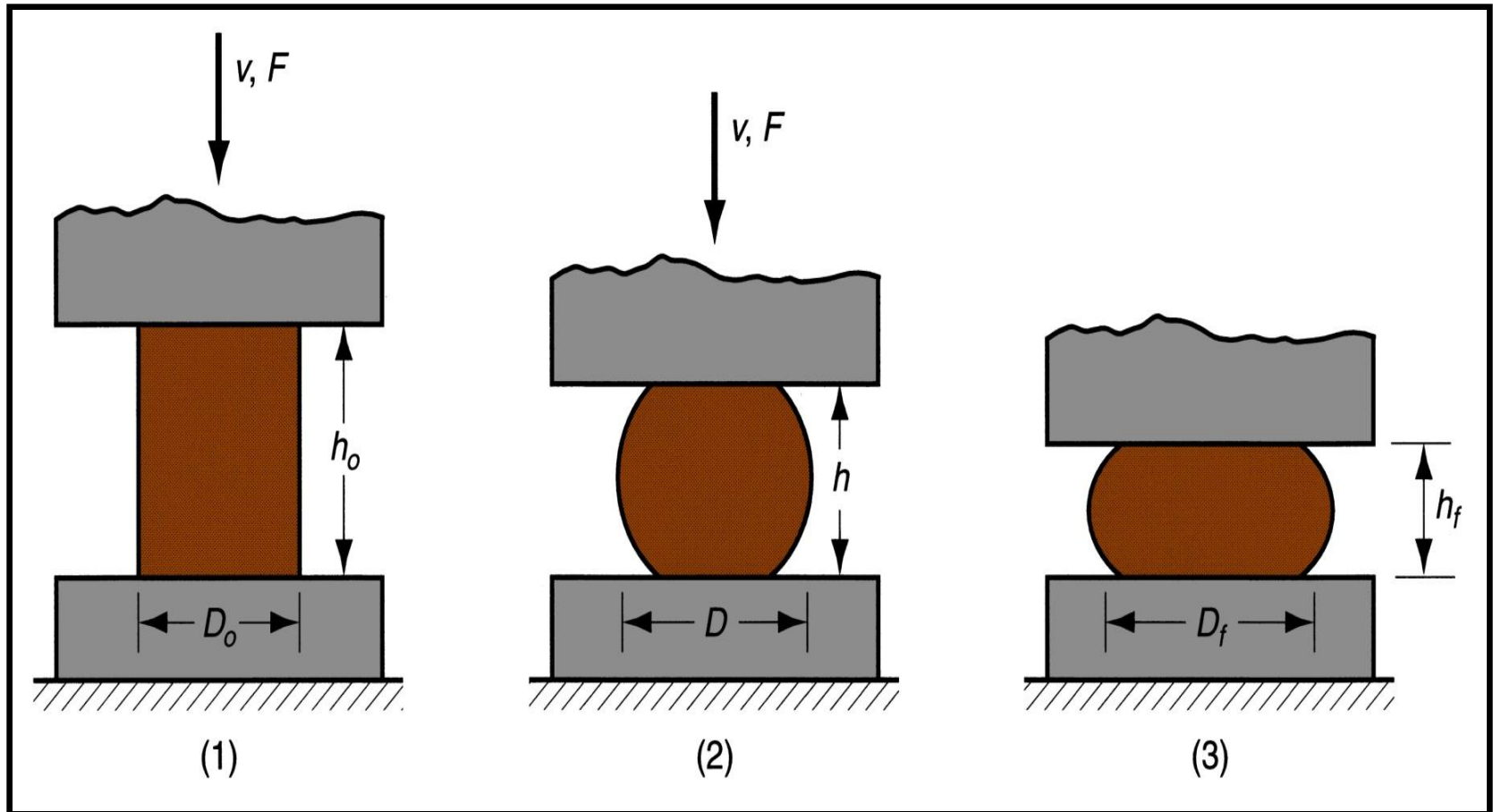

# Forging

Cogging : thickness of a bar is reduced by successive forging steps at specific intervals.

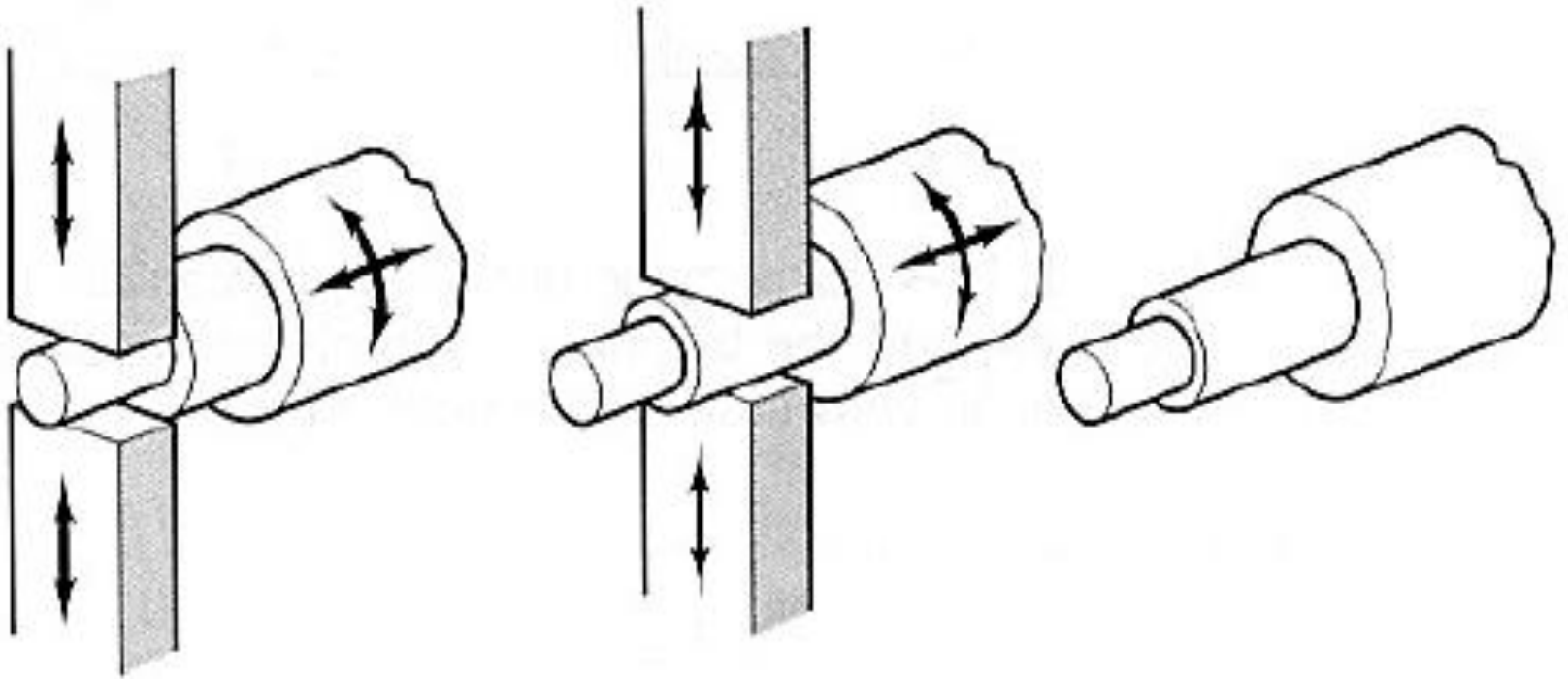

Open-die forging of a multi diameter shaft



# Forging

## Impression-die forging

- Work piece takes the shape of die cavity while being forged between two shaped dies.
- Carried out at elevated temperatures for enhanced ductility of the metals and to lower the forces.
- Some of the material flows radially outward to form a flash.

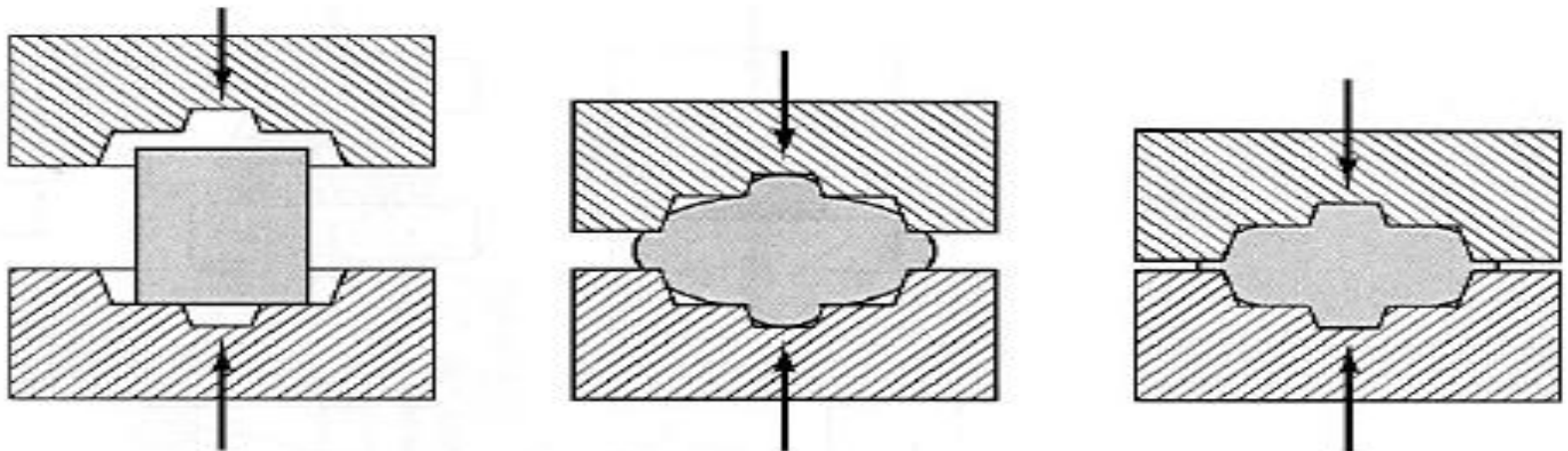

# Forging

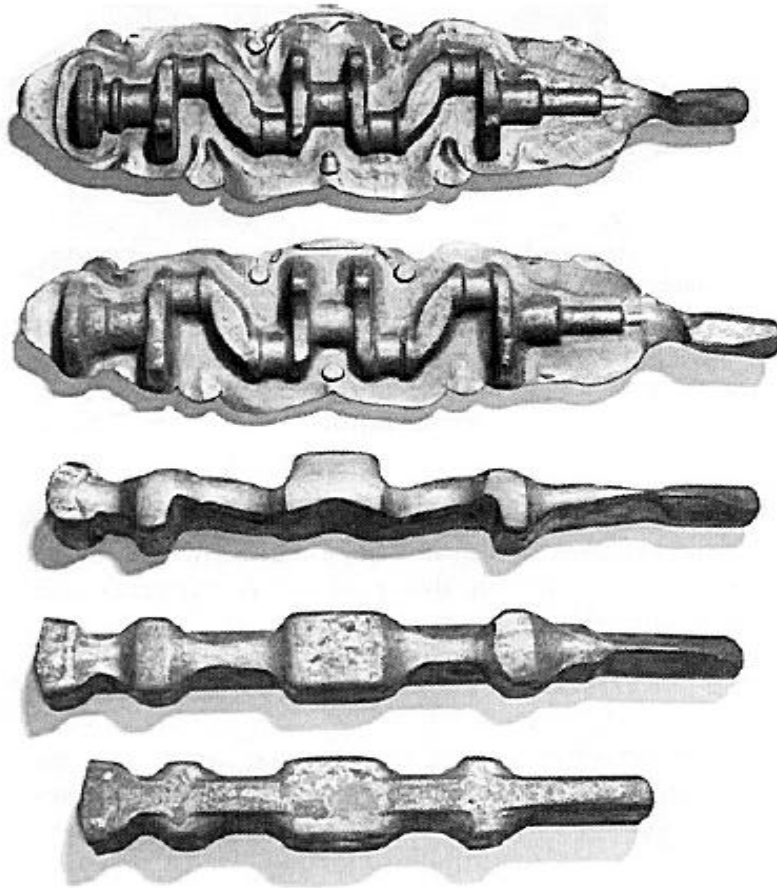

Stages (from bottom to top) in the formation of a crankshaft by hot impression-die forging

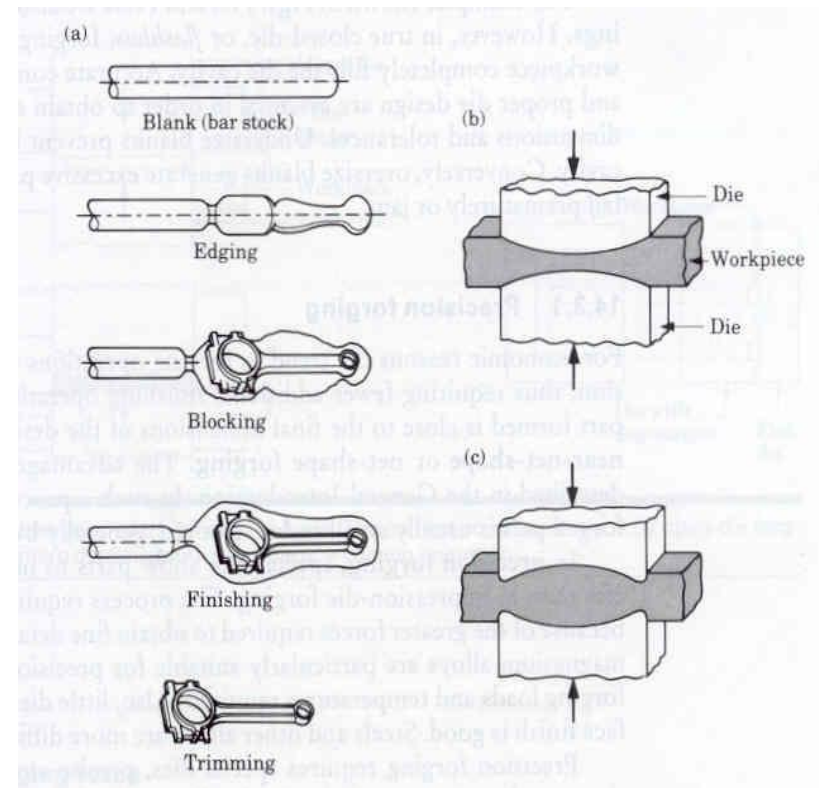

# Forging

## Closed-die / Flashless forging

- Work material is completely surrounded by the die cavity during compression and no flash is formed.
- Best suited to part geometries that are simple and symmetrical.

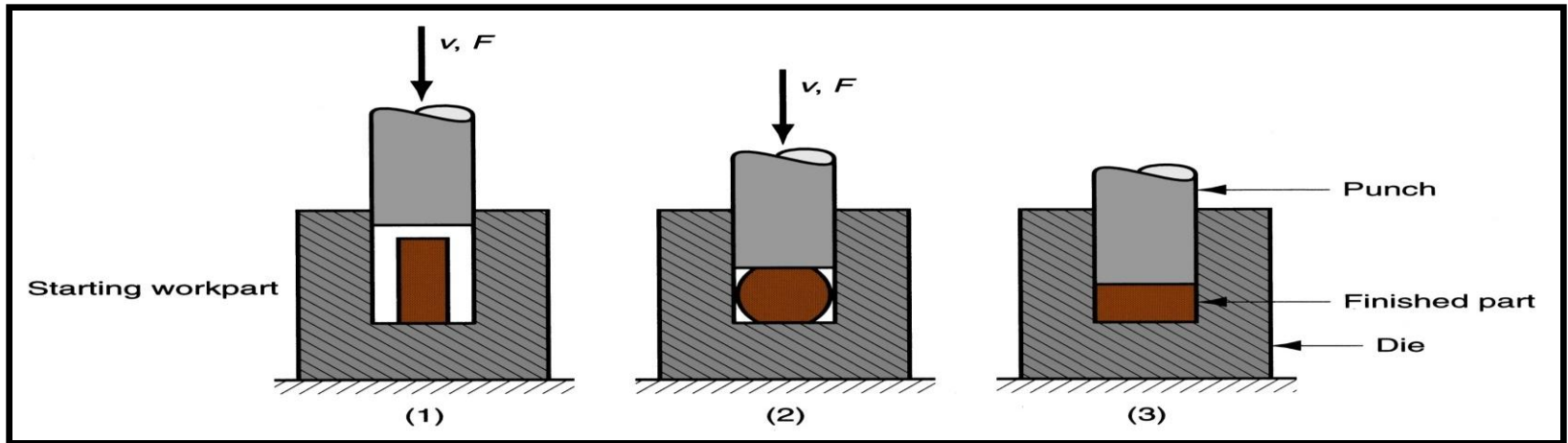

Work volume must equal the space in the die cavity to a very close tolerance.

# Extrusion

- Work is forced to flow through a die opening to produce a desired cross-sectional shape.
- Used to produce long parts of hollow or solid uniform cross-sections.
- Products then cut to the desired lengths.
- Aluminium, copper, steel, magnesium and plastics are most suitable for extrusion.
- Moderate to high die and equipment cost.
- Low to moderate labor costs and operator skill.
- Depending on the ductility of the material used, extrusions can be carries out various in ways:
  1. Hot extrusion
  2. Cold extrusion

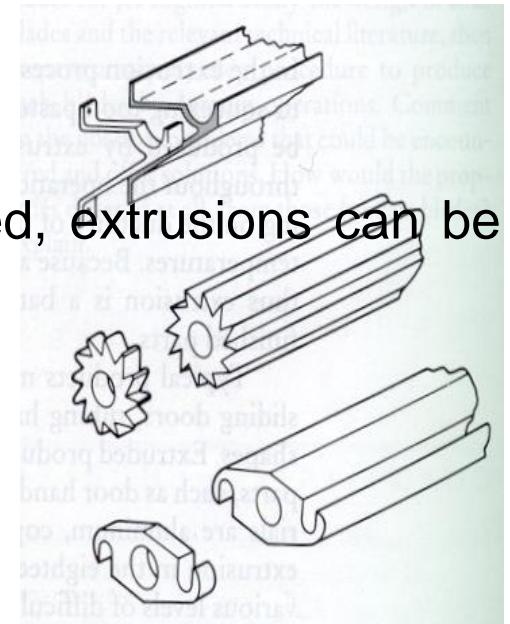

# Extrusion

## Advantages:

1. Variety of shapes possible, especially in hot extrusion.
2. Grain structure and strength enhanced in cold and hot extrusion.
3. Close tolerances possible, especially in cold extrusion.
4. In some operations, little or no waste of material.

## Disadvantages:

1. Part cross-section must be uniform throughout length.
2. Service life of extrusion tooling is shorter because of high contact stresses and slip rates.
3. Relatively high tooling costs.
4. Cost of extrusion are generally greater as compared to other techniques.

# Extrusion

## Hot Extrusion

- Carried out at elevated temperatures in 2 situations:
  1. For metals and alloys that do not have sufficient ductility at room temperature.
  2. To reduce the forces required.
- Die wear can be excessive and cooling of the hot billet in the chamber can be a problem, which results in highly non-uniform deformation.
- To reduce cooling of the billet and to prolong die life, extrusion dies may be preheated.

## Cold Extrusion

- Metals worked possess the plasticity necessary (high degree of ductility) for successful forming without heating them.
- Done to improve the physical properties of a metal and to produce a finished part.
- It is fast, no wastes or little materials and gives higher accuracy and tolerance.

# Extrusion

## Direct Extrusion

- Billet is placed in the container and a ram towards the die pushes it.
- Metal slides along the walls of the container and is forced to flow through die opening.
- At the end of the extruding operation, a small piece of metal, called butt-end scrap, remains in the container and cannot be extruded.

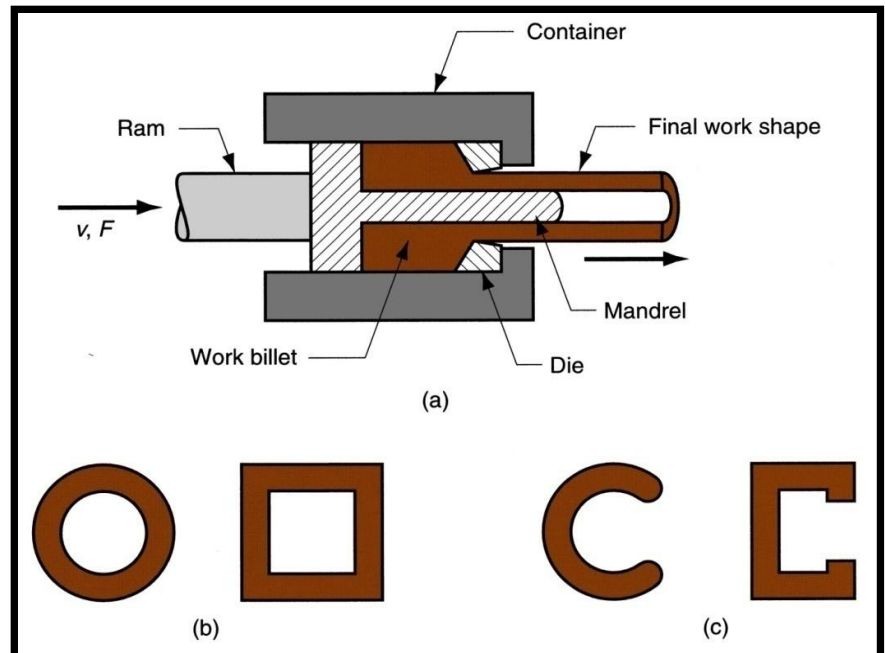
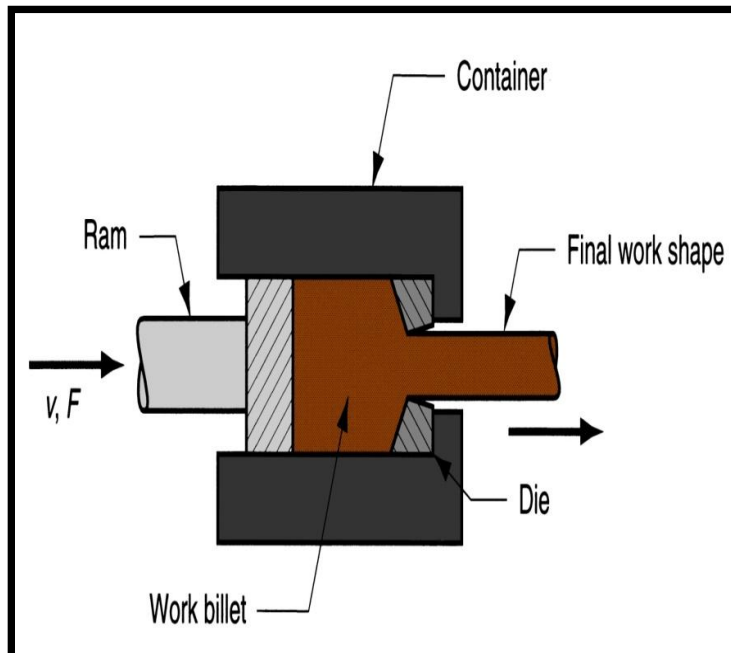

# Extrusion

## Indirect / Hydrostatic Extrusion

- Die is mounted on the end of a hollow ram and enters the container.
- The outer end of container being closed by a closure plate.
- As the ram travels, the die applies pressure on the billet and the deformed metal flows through the die opening in the direction opposite to the ram motions and the product is extruded through the hollow ram.

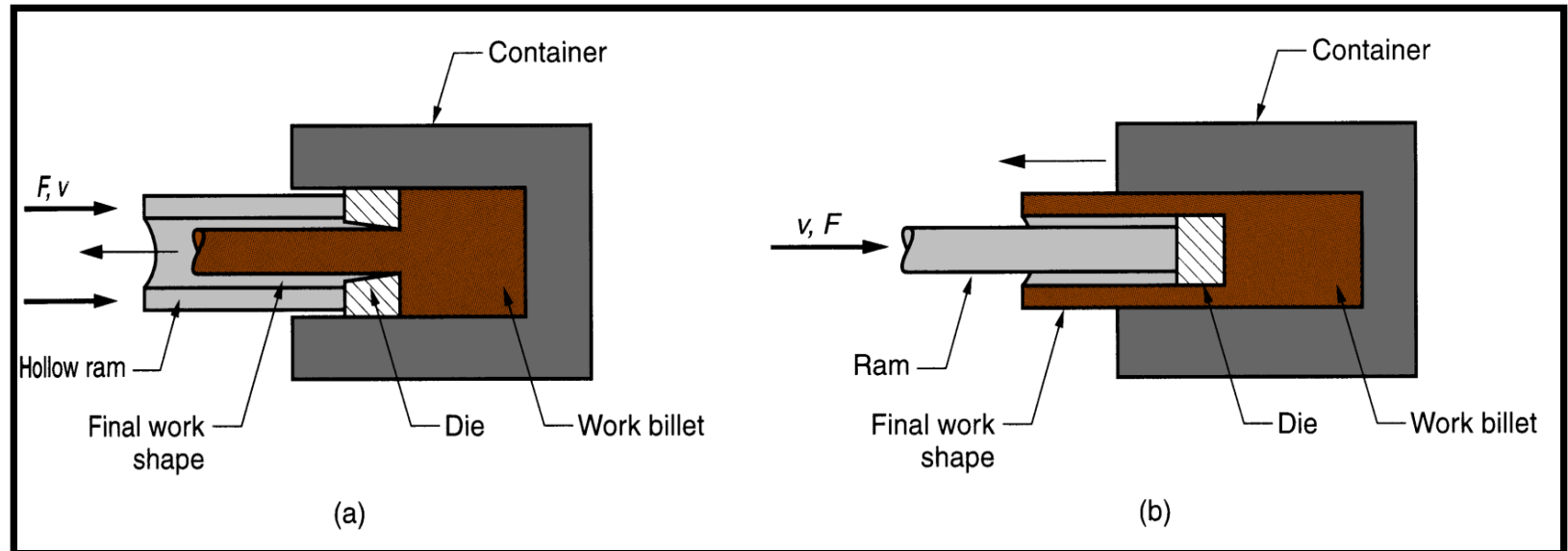



# Extrusion

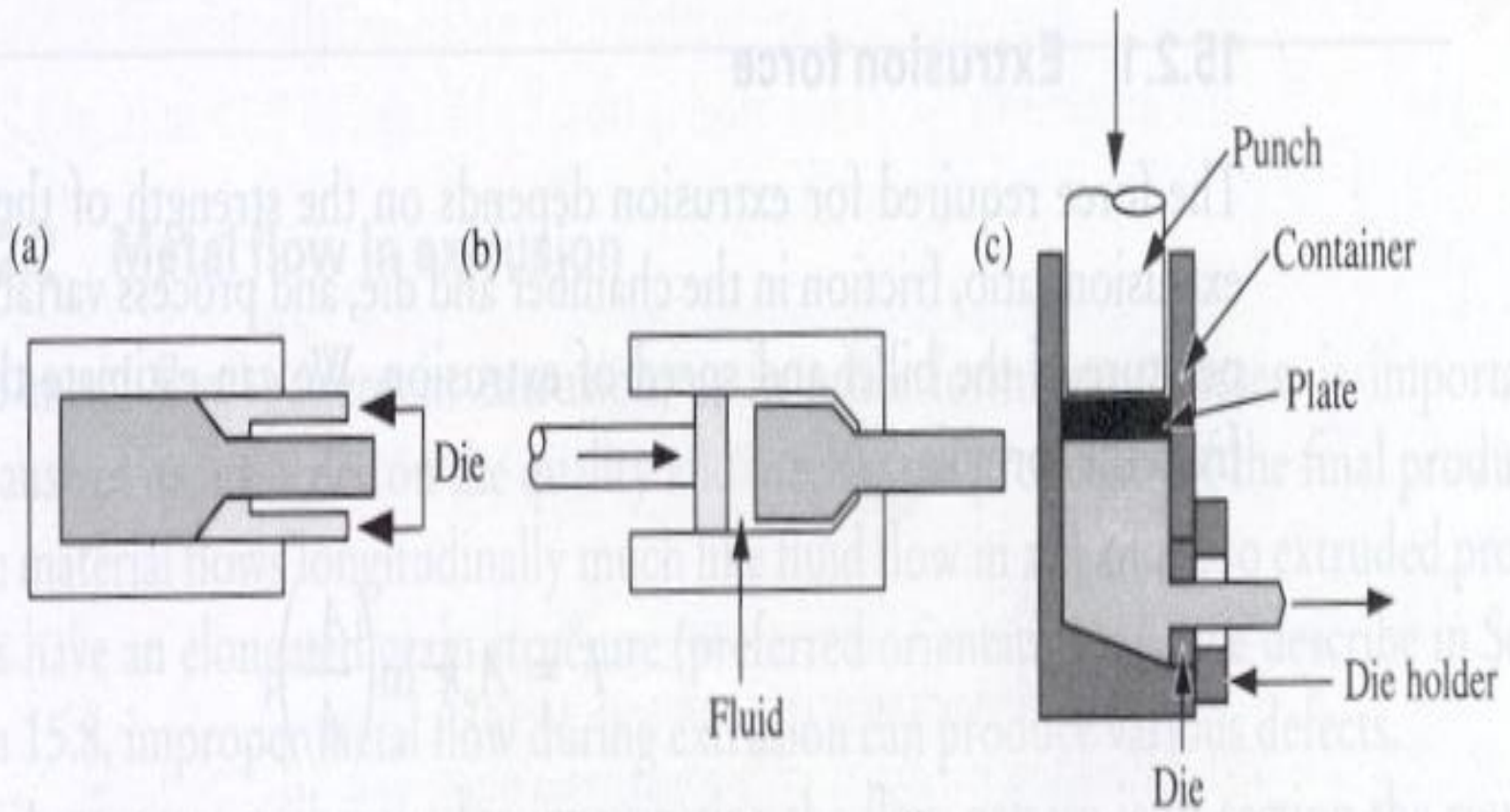

Indirect

Hydrostatic

Lateral

# Drawing

- Production of long rod, wire and tubing with round or various cross-section than extrusions by pulling the material through a die opening.
- Similar to extrusion except work is *pulled* through die in drawing (it is *pushed* through in extrusion).

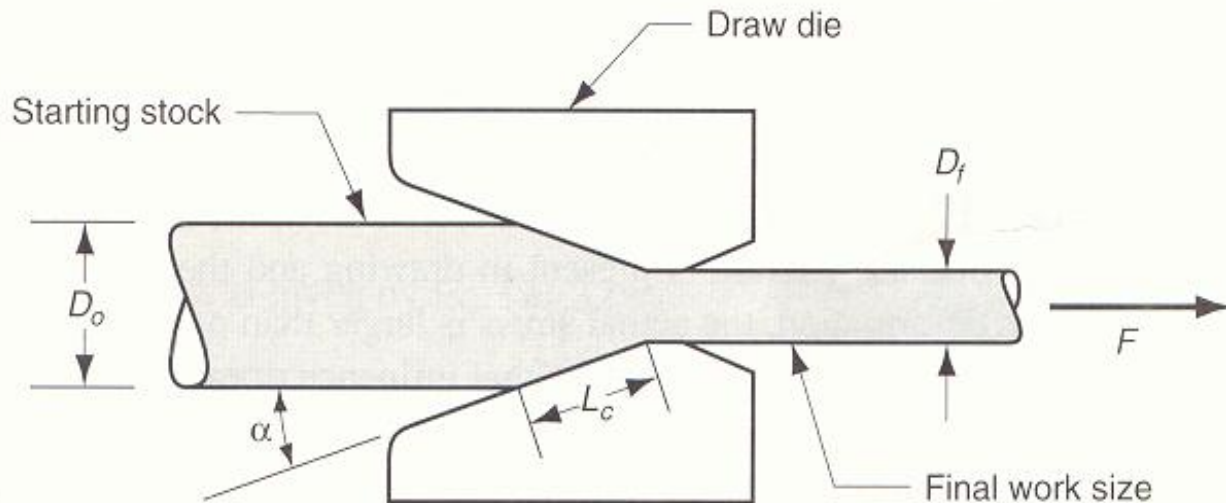

# Drawing

## Drawing Practice:

- Usually performed as cold working
- Most frequently used for round cross-sections

## Products:

- Wire : electrical wire; wire stock for fences, coat hangers and shopping carts
- Rod stock : nails, screws, rivets, and springs
- Bar stock : metal bars for machining, forging and other processes

## Wire Drawing vs Bar Drawing

- Difference is the stock size:
  - Bar drawing - large diameter bar and rod stock
  - Wire drawing - small diameter stock - wire sizes down to 0.03 mm (0.001 in.) are possible

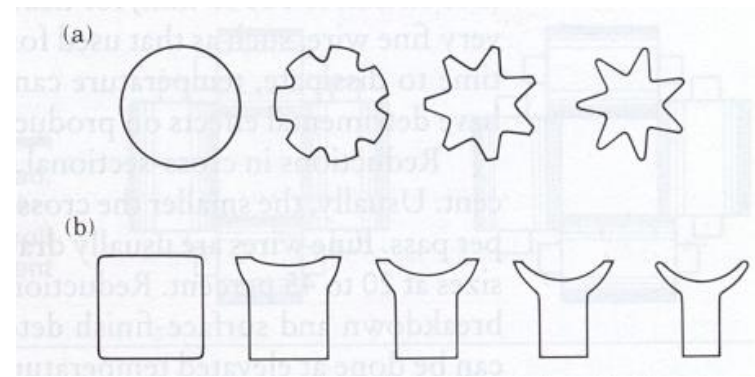

# Rolling

- Process of reducing the thickness or changing the cross-section of a work-piece by compressive forces exerted by a pair of rotating rolls.
- Products: plates & sheets - plates are used for structural applications like bridges, ships and nuclear vessels while sheets (generally 6mm or less in thickness) are used for automotive, beverage cans, office & kitchen equipment.

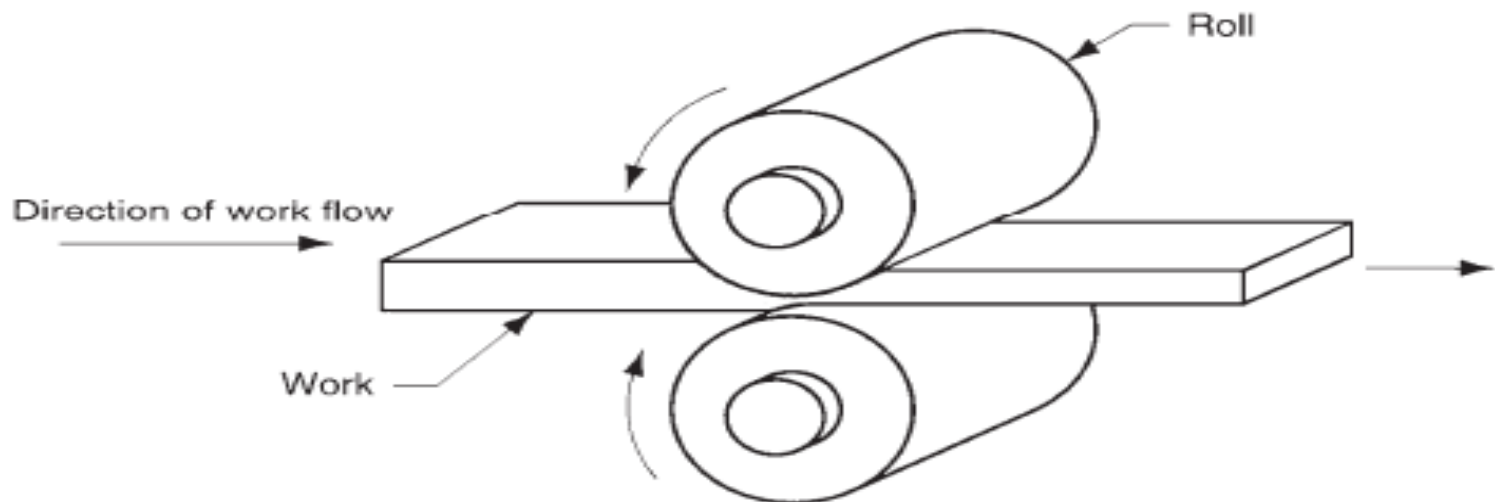

# Rolling

## Steps of Rolling

- The preheated at 1200°C cast ingot is rolled into one of the three intermediate shapes called:
  1. Bloom – square cross-section of 150/150 mm or more
  2. Slab – 40/250 mm or more is rolled from an ingot or a bloom
  3. Billet – 40/40 mm or more is rolled from a bloom
- Then they are rolled into a different products.

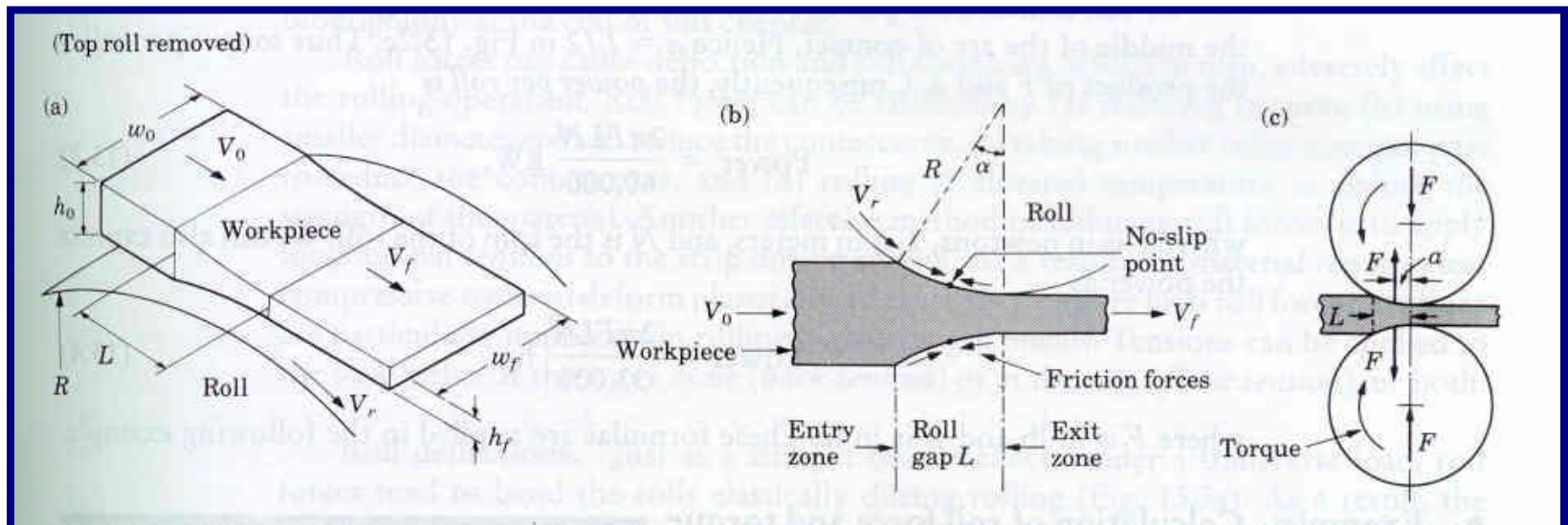

# Rolling

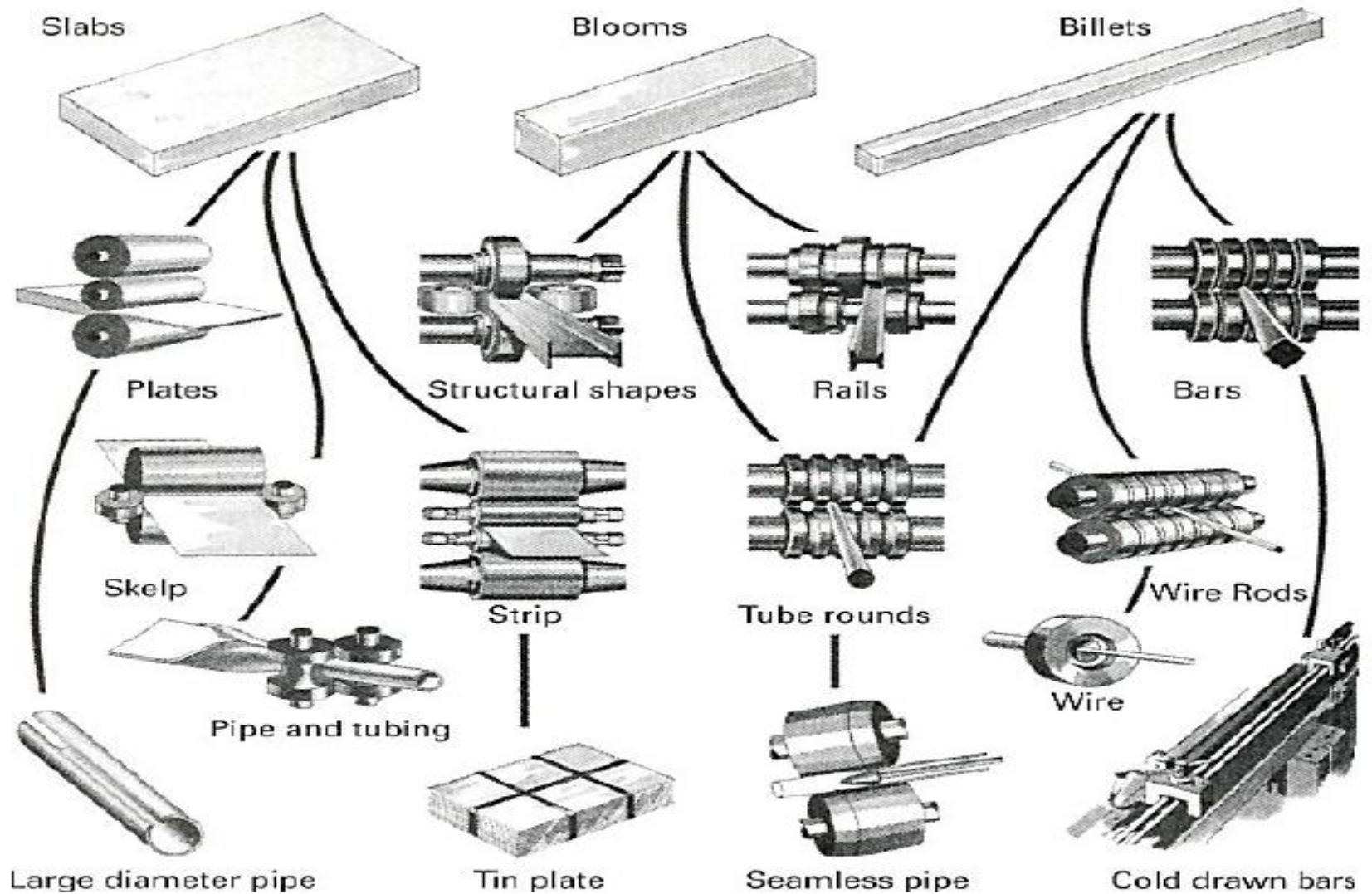

Production steps in rolling

# Rolling

## Basic types of rolling

### 1. Shape Rolling

- Work is deformed by a gradual reduction into a contoured cross section (I-beams, L-beams, U-channels, rails, round, square bars and rods, etc.).

### 2. Ring Rolling

- Thick-walled ring of small diameter is rolled into a thin-walled ring of larger diameter.

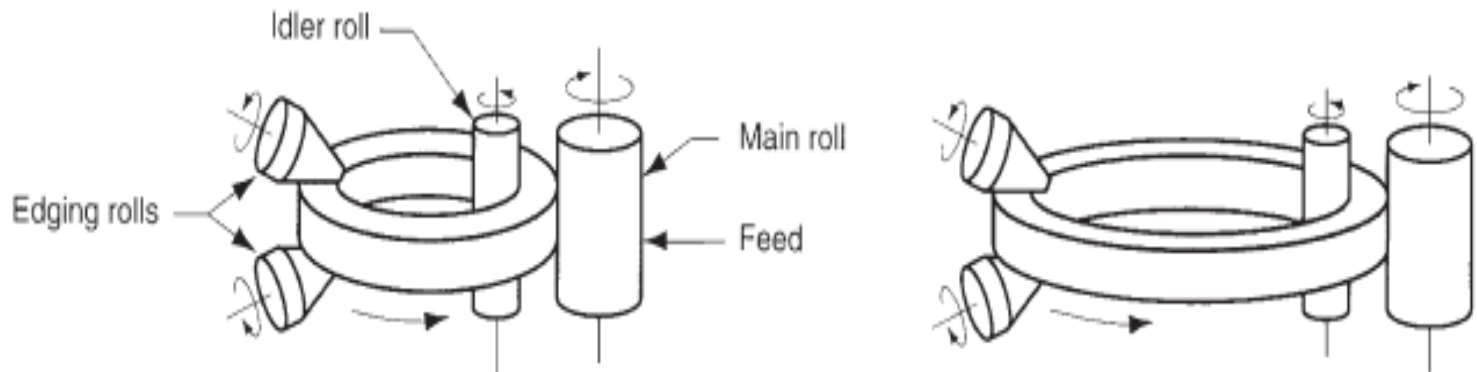

Ring rolling used to reduce the wall thickness and increase the diameter of a ring

# Shape Rolling

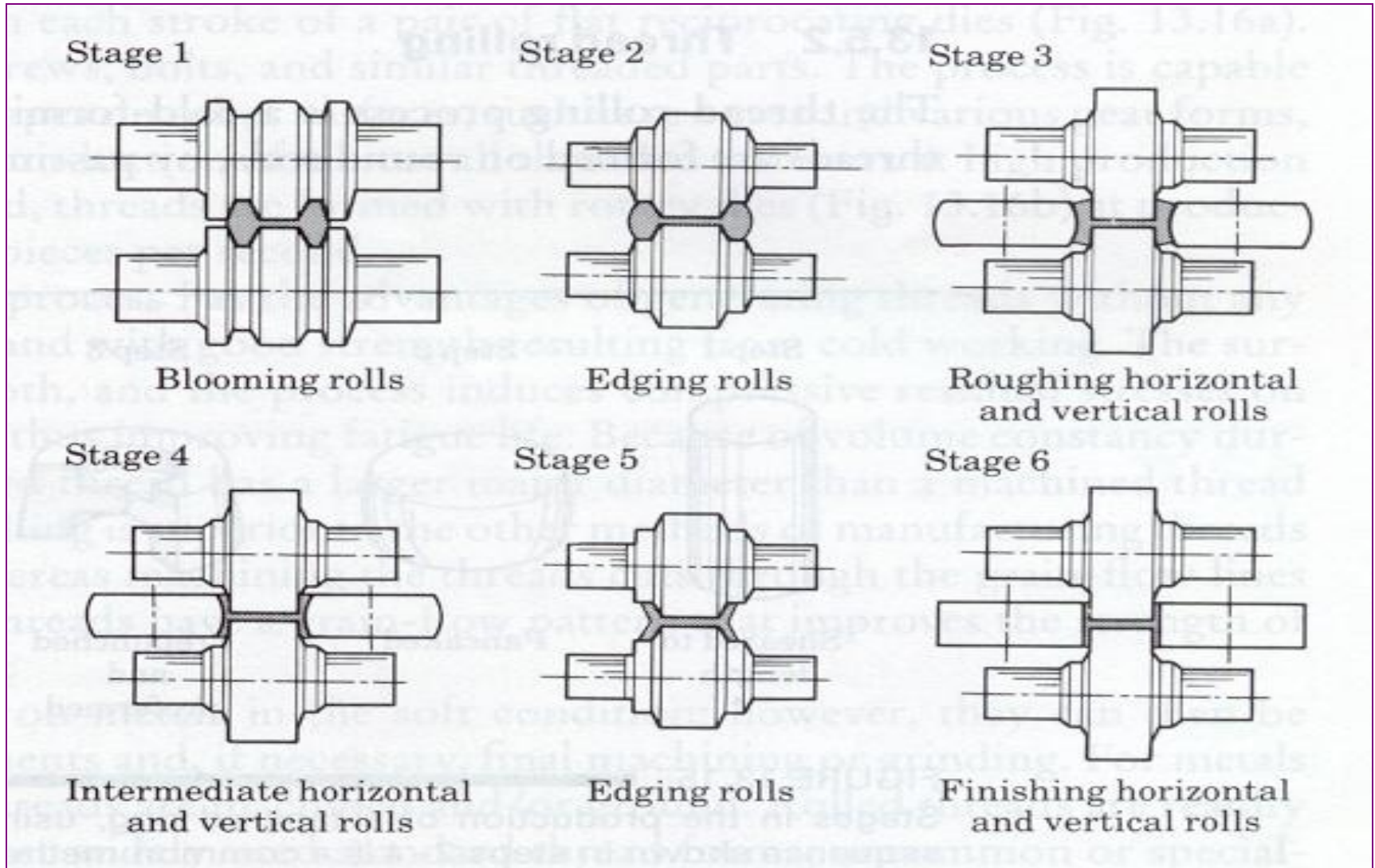



# Rolling

## 3. Thread Rolling

- Threads are formed on cylindrical parts by rolling them between two thread dies.

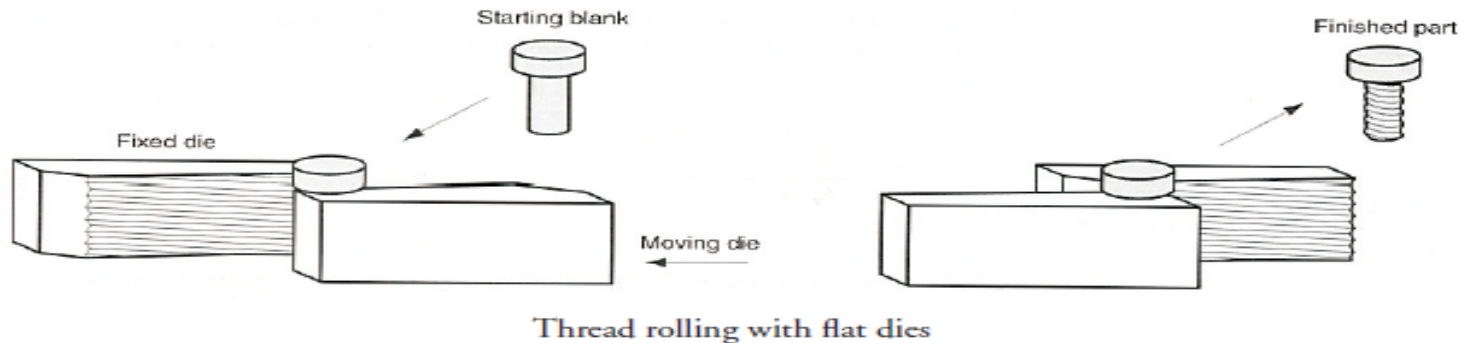

## 4. Gear Rolling

- Gear rolling is similar to thread rolling with three gears (tools) that form the gear profile on the work.

